

ABSTRACT

Transmission line protection is an important issue in power system because 85-87% of power system faults are occurring in transmission line. This dissertation work gives technique to classify the different faults on transmission line for quick and reliable operation of protection schemes. It also a new technique for fast and accurate detection as well as classification of power system faults using modern signal processing techniques. The technique involves wavelet analysis of faulty voltage and current waveforms, which are recorded at a suitable monitoring location in multi-bus power system to gather valuable information required in detection and classification of faults.

Transmission line faults are of mainly five types: L-G, L-L, L-L-G, L-L-L and L-L-L-G. But the effect of L-L-L and L-L-L-G faults is same. So, here we are considering only L-L-L fault. In all four different faults are classified after faulty condition is detected in the system.

With the advent of computers, it becomes easier to simulate a power system in various software's available for simulation. Today, various simulation software's like PSCAD, ATP and MATLAB/SIMULINK are available in the market. In this project, I have considered 'Standard IEEE System' and simulated it in PSCAD/EMTP software. The data obtained from simulation is exported to the Wavelet Toolbox of MATLAB for acquiring the various parameters like presence of harmonics and overvoltage.

INTRODUCTION

Protection against the transmission line fault is an important issue in electrical power system, because most of fault occurs on transmission line. So discrete wavelet transform are applied for decomposition of fault transient, because it's ability to extract the fault information from transient signal. ANN is the best approach in determining the correct fault type. The choice of protection depends upon several aspects such as type and rating of protected equipment, its importance, location, probable abnormal conditions, cost etc.

In electric power systems comprising of different complex interacting elements, there always exists the possibility of disturbances and faults. The advent of large generating stations and highly interconnected power systems makes early fault detection and rapid equipment isolation imperative to maintain system stability. Faults on power transmission lines need to be detected and located rapidly, classified correctly and cleared as fast as possible. In a poly phase system different types of faults are categorized as: i) line-to-line (LL) fault due a short circuit between lines, ii) single line-to-ground (SLG) fault caused by a short circuit between one line and ground, and iii) double line to- ground (DLG) fault, when two lines come into contact with the ground. Protecting the system from these faults demands two major tasks: i) fault detection and ii) fault clearing, which involve detection of a fault including determination of the fault location and subsequently fault classification. When the type of fault is correctly identified, the possible remedial action can quickly be sorted out to solve the problem.

Operation of relays which detect abnormal power system conditions, and initiate corrective action as quickly as possible in order to return the power system to its normal state. A precise protection scheme is required in order to ensure the extreme level of the system reliability. Distance relays are normally used to protect transmission lines. The impedance between the relay location and the fault location that is fairly constant, these relays respond to the distance to a fault on the transmission line. During the course of recent years, the development of the fault

diagnosis for the transmission line has been progressed with the applications of signal processing techniques and artificial Transmission and distribution networks are the important components of power system network. Electric power systems are constantly affected with faults which disturb the system's reliability, security and delivered energy quality.

NECESSITY OF EHV TRANSMISSION LINE

All developed and developing countries depend upon electrical energy for industrial, commercial, agricultural, domestic and social purposes. Therefore, the basic infrastructure, that is, generating stations and transmission and distribution lines have become a crucial part of modern socio-industrial landscape. Hydropower sites, however, are located far away from load centers while thermal plants are located near coal mines, for economic reasons and also to avoid pollution. Hence, the energy produced at the generating stations has to be transmitted over long distances to load centers through transmission systems. This transmission can be done more economically by using extra high-voltage (EHV) transmission.

Discrete Wavelet Transform

Wavelet theory is the mathematics, which deals with building a model for non-stationary signals, using a set of components that look like small waves, called wavelets. It has become a well-known useful tool since its introduction, especially in signal and image processing. The DWT is easier to implement than Continuous Wavelet Transform CWT because CWT is computed by changing the scale of the analysis window, shifting the window in time, multiplying the signal and the information of interest is often a combination of features that are well localized temporally or spatially This requires the use of analysis methods sufficiently, which are versatile to handle signals in terms of their time-frequency localization. Frequency based analysis has been common since Fourier's time; however frequency analysis is not ideally suited for transient analysis, because Fourier based analysis is based on the sine and cosine functions, which are not transients . These results in a very wide frequency spectrum in the analysis of transients Fourier techniques cannot simultaneously achieve good localization in both time and frequency for a transient signal. The main advantage of WT over Fourier Transform is that the size of analysis window varies in proportion to the frequency analysis. WT can hence offer a better compromise in terms of localization. The wavelet transform decomposes transients into a series of wavelet components each of which corresponds to a time domain signal that covers a specific octave frequency band containing more detailed information . Such wavelet components appear to be useful for detecting, localizing, and classifying the sources of transients. Hence, the wavelet transform is feasible and practical for analyzing power system transients. Figure 2 shows the high frequency and low frequency splitting of transient signal.

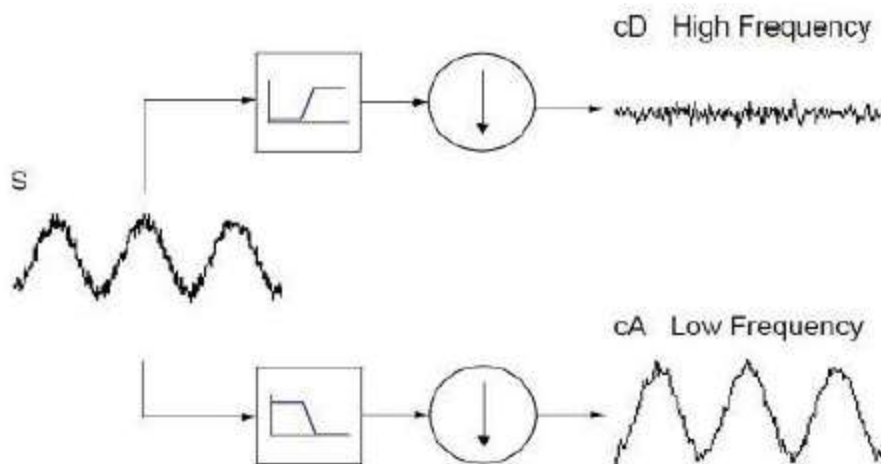
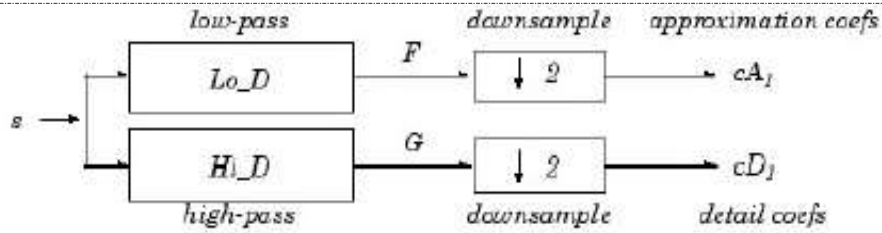

Fig1: Analysis Of Signal using Discrete wavelet Transform



where

X	Convolve with filter X
↓ 2	Keep the even indexed elements (We call this operation <i>downsampling</i> .)

One-Dimensional DWT

Decomposition step

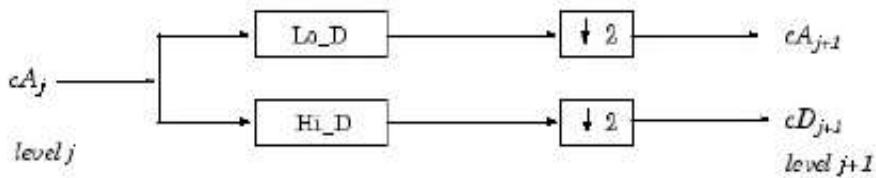

Fig 2 : DWT Framework

System Under Study

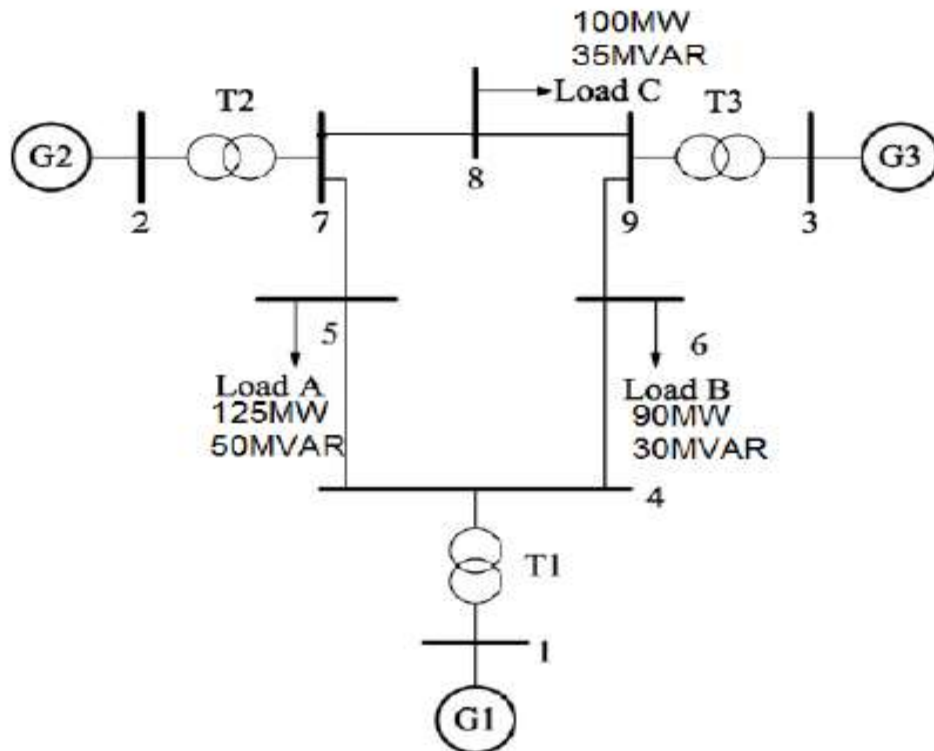

Fig 3 : IEEE 9 Bus System

PROPOSED METHODOLOGY

Transmission line protection is an important issue in power system because 85-87% of power system faults are occurring in transmission line. This dissertation work gives technique to classify the different faults on transmission line for quick and reliable operation of protection schemes.

Transmission line faults are of mainly five types: L-G, L-L, L-L-G, L-L-L and L-L-L-G. But the effect of L-L-L and L-L-L-G faults is same. So, here we are considering only L-L-L fault. In all four different faults are classified after faulty condition is detected in the system.

In this dissertation work standard IEEE 9 bus system is taken under study. This network is simulated in PSCAD software. Four faults at different location and different inception angles are created. Current waveform and voltage waveforms are captured for the transmission line. Datasheet is prepared in PSCAD software is then imported to MATLAB for DWT analysis. Calculation of modal signal is done and energy is calculated from the detailed coefficient obtained after decomposition. Classification of various faults is done using ANN.

- i) The faults are created on the IEEE Standard bus system between the range of 1m.
- ii) The fault readings are taken in a interval of 0.25 km on four locations on this transmission line at various inception angle 0 , 45 and 90 degrees.
- iii) Simulation of system under study in PSCAD/EMTDC software.
- iv) Capturing of voltage and current signals and preparation of data sheet from simulation software with 10KHz sampling frequency.
- v) Normalized the voltage and current signals.
- vi) Construct a modal signal.
- vii) Importing of datasheet to MATLAB programming for DWT analysis.
- viii) Decomposition of captured signal by using db4 wavelet up to 7th level.
- ix) Calculation of energy from the detailed coefficient for 7th levels.
- x) Preparation of data sheet of d6 energy level and importing it to ANN.
- xi) Classification of faults is done by using ANN.

Artificial Neural Network

The application of artificial neural networks to discriminate the fault has given a lot of attention recently. This chapter describes the preliminaries of neural network, basic architecture of neural network, brief discussion on different neural networks, algorithm and training function.

The simplest definition of a neural network, more properly referred to as an 'artificial' neural network (ANN), is provided by the inventor of one of the first neuro computers, Dr. Robert Hecht-Nielsen. He defines a neural network as: "...a computing system made up of a number of simple, highly interconnected processing elements, which process information by their dynamic state response to external inputs."

An Artificial Neural Network (ANN) is an information-processing paradigm that is inspired by the way biological nervous systems, such as the brain process information. The key element of this paradigm is the novel structure of the information processing system. It is composed of a large number of highly interconnected processing elements (neurons) working in union to solve specific problems. ANN's, like people, learn by example. An ANN is configured for a specific application, such as pattern recognition or data classification, through a learning process. Learning in biological systems involves adjustments to the synaptic connections that exist between the neurons. This is true of ANN's as well.

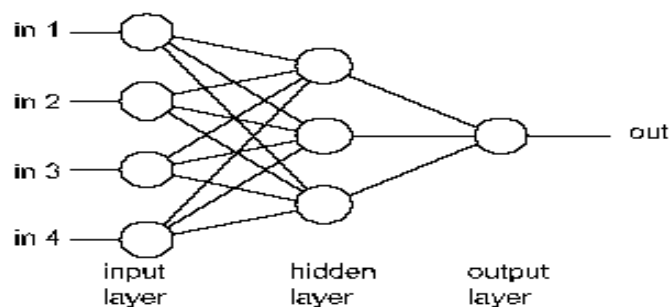

Fig 4: ANN Network

RESULTS AND DISCUSSION

The IEEE standard 9 bus system is taken for study. The simulation is done in PSCAD software as it is best suited for all types of transients and faults. The artificial Neural Network is used as a classifier to classify various faults occurring on the system. The faults are created on Bus 4 between 1 metre range at a distance of 0.25 metre at equal four locations also at the incipient angles of 0,45 and 90 degrees. The generated voltage and current waveforms are recorded after simulation in PSCAD and decomposed in MATLAB with the help of Discrete Wavelet Transform in various frequency band ranges. The various energy levels are calculated and extracted in the form of excel data and given as input to ANN as classifier. Due to which the various faults are classified. The results of simulation are as follows

All the fault cases are discussed in the results initially all the types of faults are made between bus 4 and bus 5 at three inception angles as 0 degree 45 degree and 90 degree. The cases of faults made at a distance of 0.5m is considered for the result analysis.

Fig shows the simulation waveforms of line to line fault (L-L) at 0.5 m between bus 4 and bus 5 at an inception angle of 0 degree. The graph shows the nature of voltages of bus 4 i.e E4 and Bus 5 i.e E5 and fault current IL1. The faulted waves of current and voltages can be observed during line to fault.

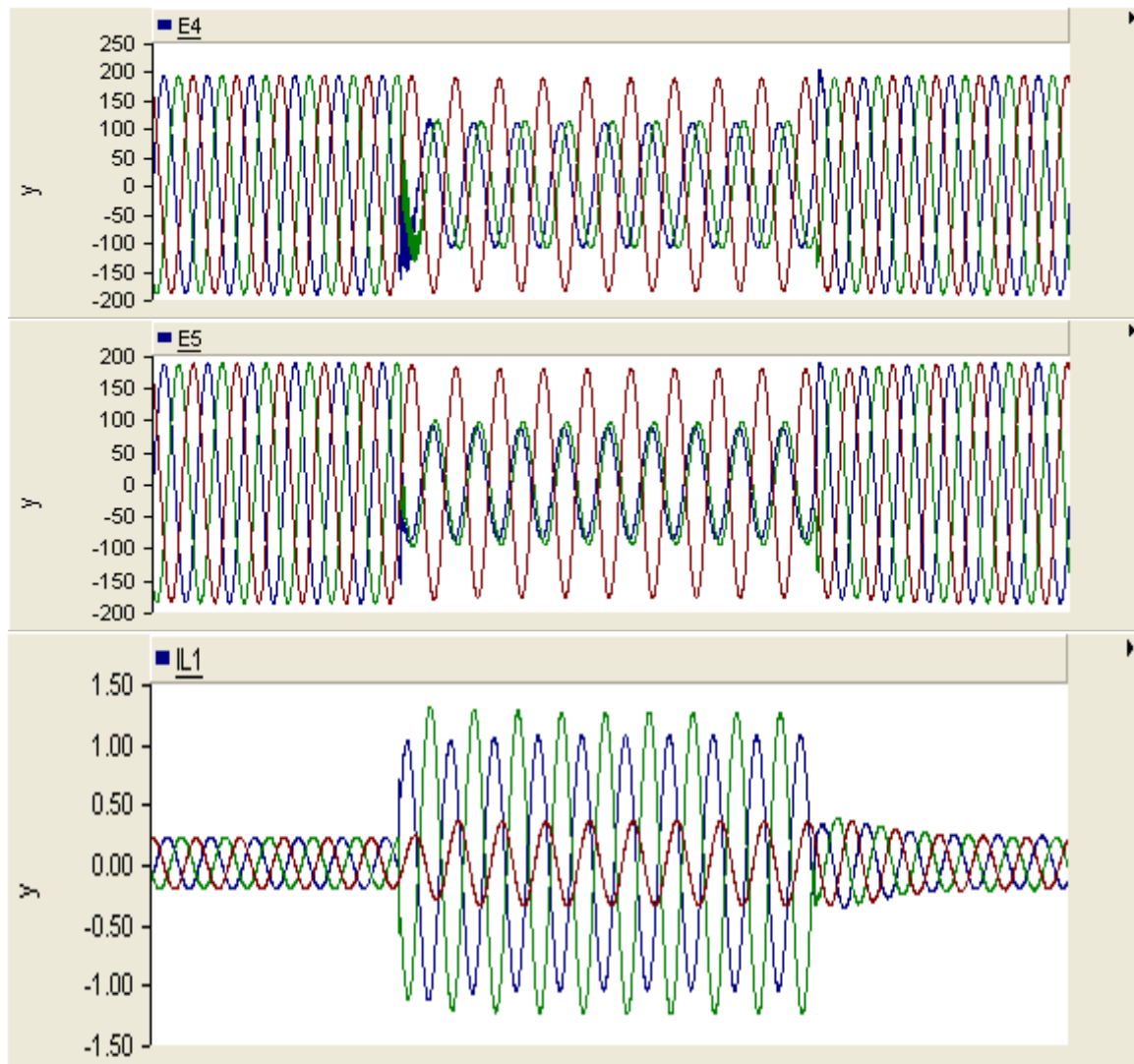

Fig shows the simulation waveforms of line to line fault (L-L) at 0.5 m between bus 4 and bus 5 at an inception angle of 45 degree. The graph shows the nature of voltages of bus 4 i.e E4 and Bus 5 i.e E5 and fault current IL1. The faulted waves of current and voltages can be observed during line to fault.

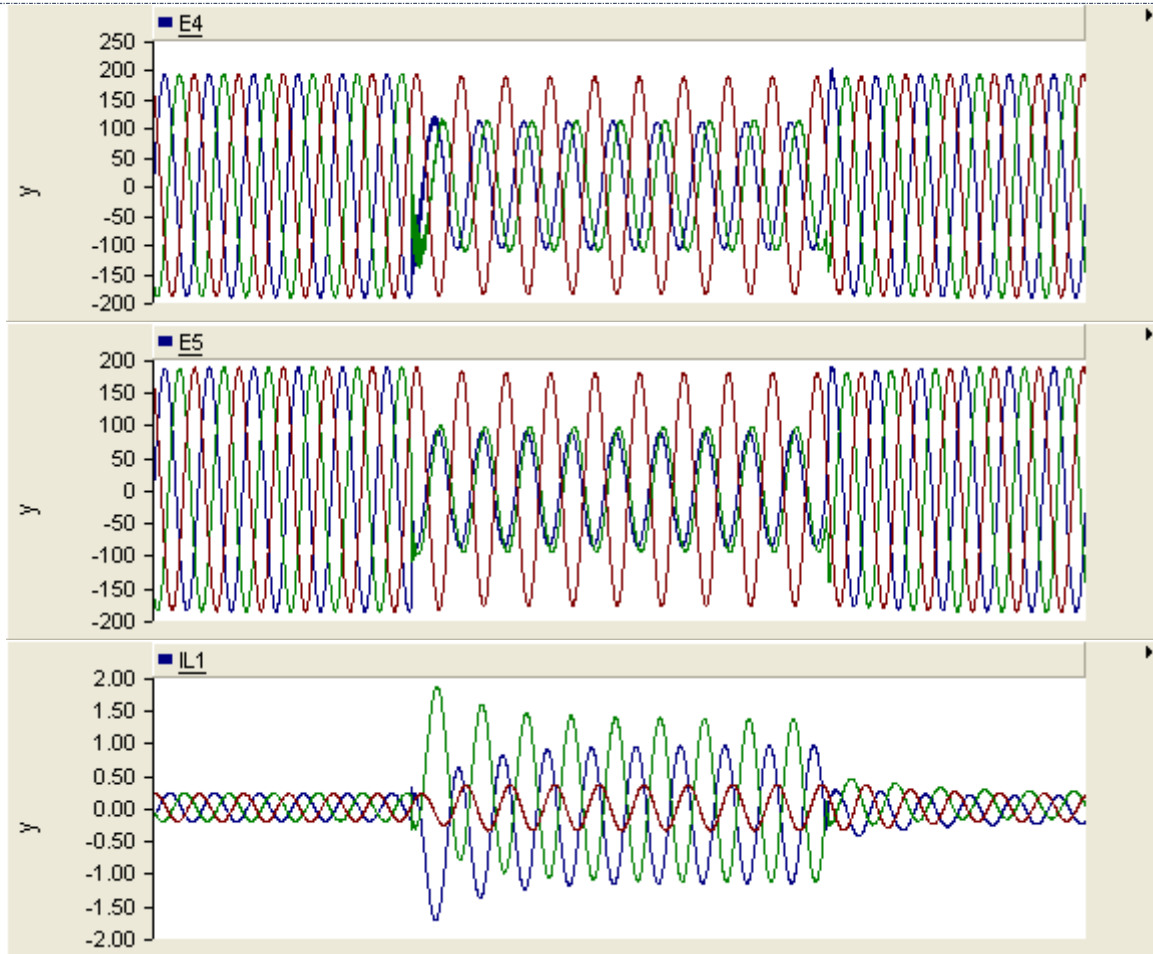
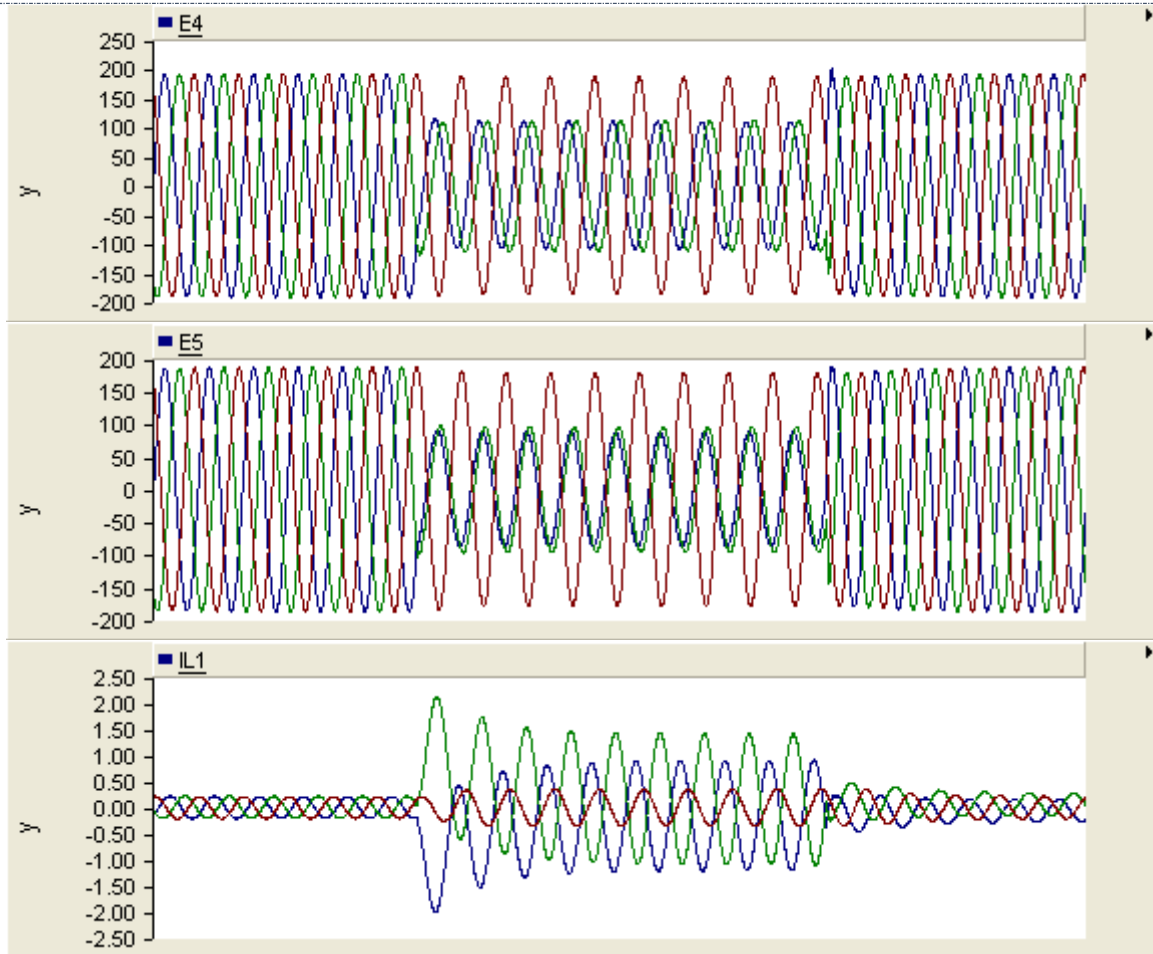
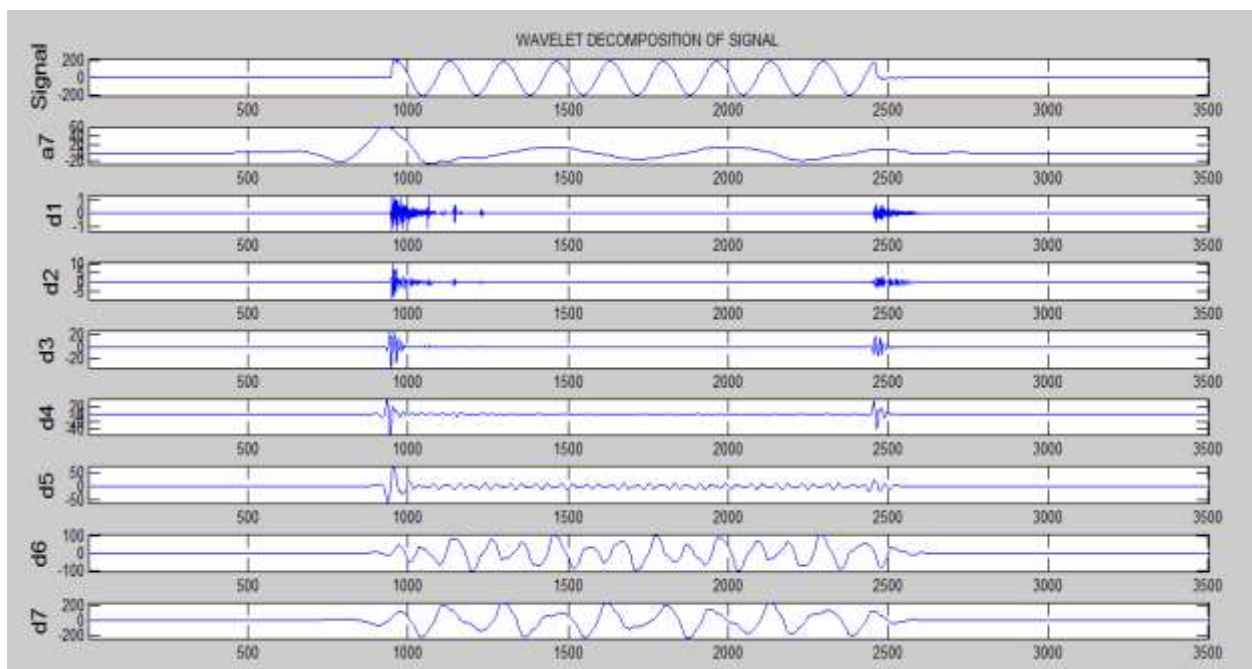

Fig shows the simulation waveforms of line to line fault (L-L) at 0.5 m between bus 4 and bus 5 at an inception angle of 90 degree. The graph shows the nature of voltages of bus 4 i.e E4 and Bus 5 i.e E5 and fault current IL1. The faulted waves of current and voltages can be observed during line to fault.



*Discrete wavelet transform Decomposition results for various frequency bands
AG fault 0 degree 0.5M locations*



ABG fault 0 degree all locations

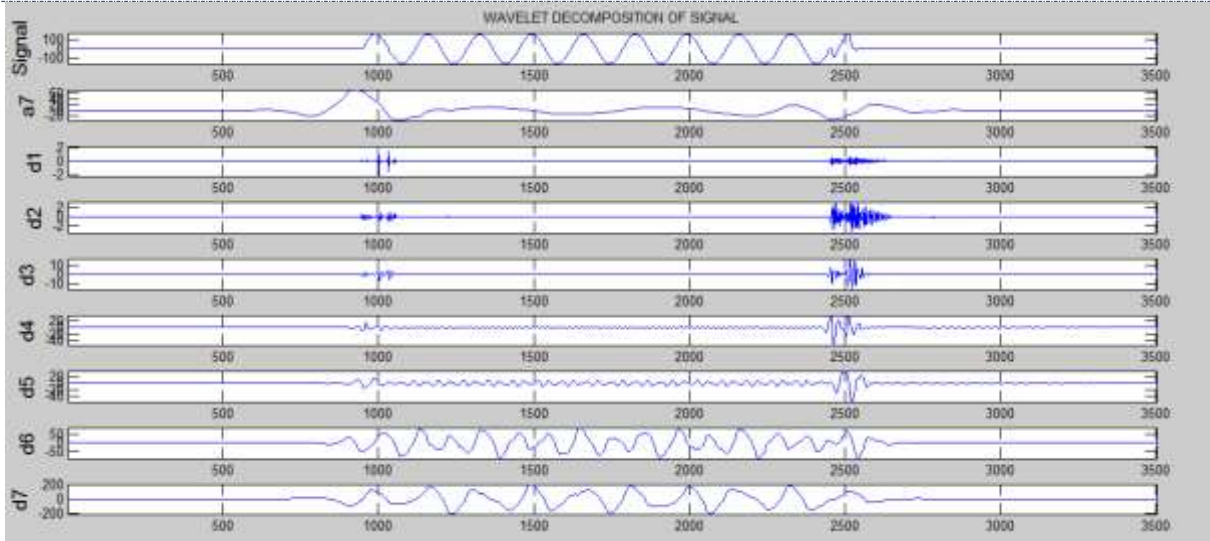

AB fault 0 degree all locations

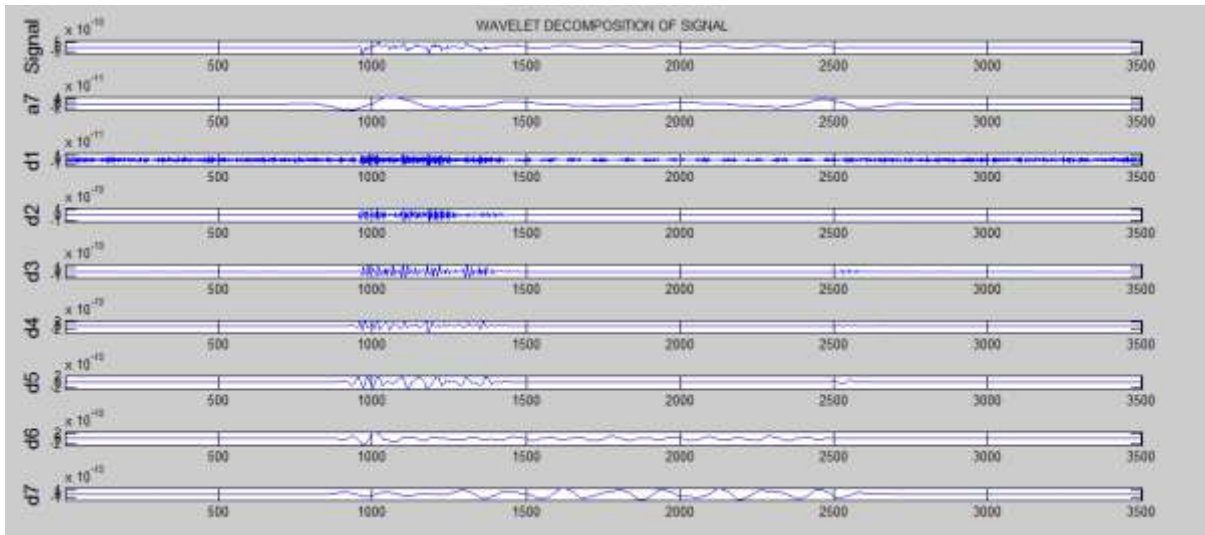

ABC fault for 0 degree all locations 0.5 m

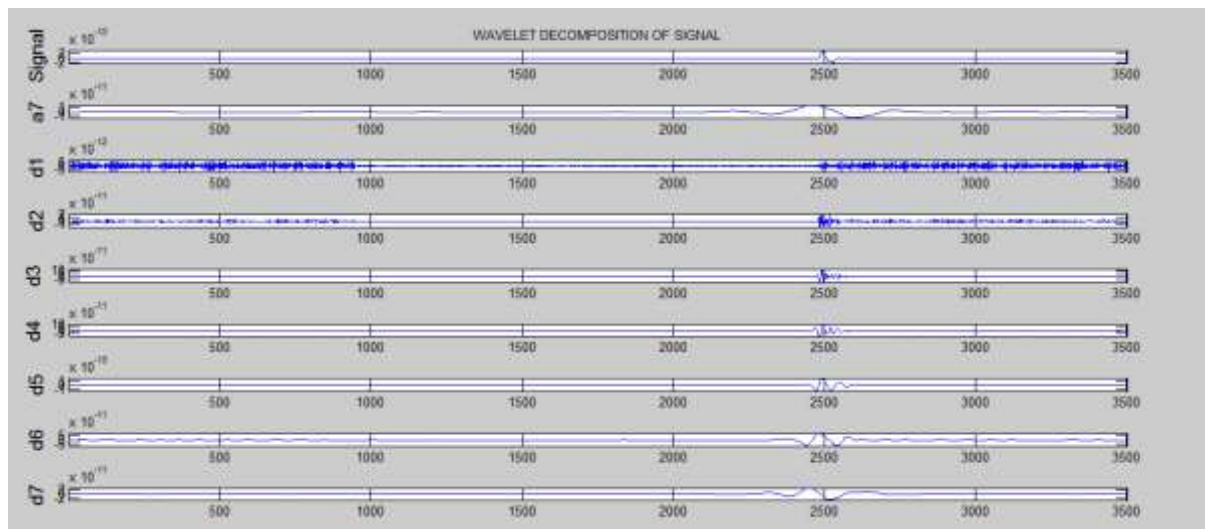

The matrix are the output of bus 4 voltage E4 , bus 5 voltage E5 and the current IL.

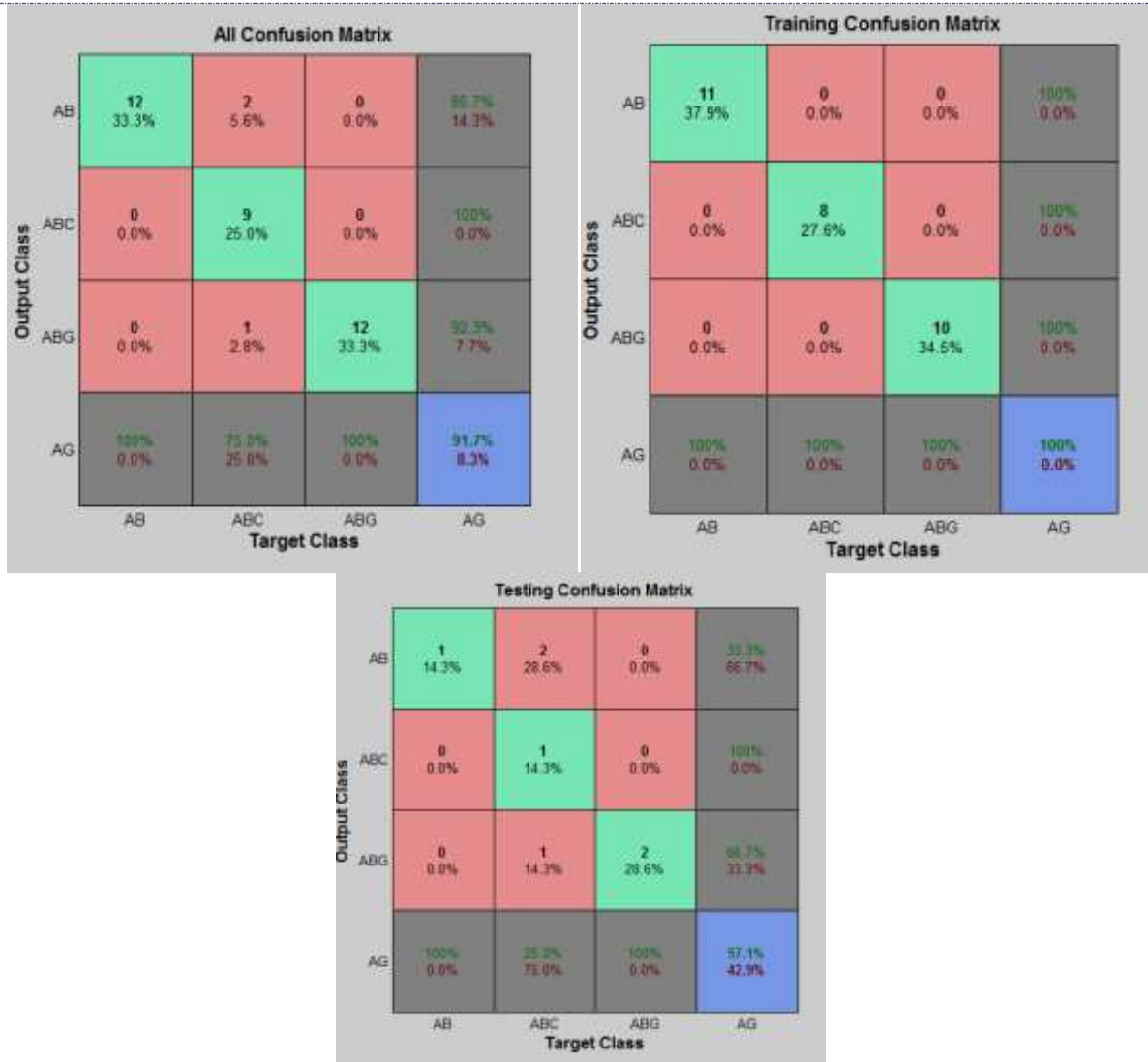

CONCLUSION

In this paper accurate fault detection and fault classification technique is designed. This technique depends upon the current signals. The features are extracted from the current signals by using wavelet transform. The feature vector is then given as input to the neural network. The capabilities of neural network in pattern classification were utilized. Simulation studies were performed and the performance of the scheme with different system parameters and conditions was investigated. Though the paper deal with fault classification can be extended to other power system protection problems such as finding fault location.

REFERENCES

- [1] M. Tarafder Hagh, K. Razi, and H Taghizadeh, "Fault Classification and Location of Power Transmission Lines using Artificial Neural Network ", The 8th International Power Engineering Conference, 1109-1114, 2007
- [2] O. Dag, and C. Ucak, "Fault Classification for Power Distribution Systems via a Combined Wavelet-Neural Approach", IEEE, 1309-1304, 2004.
- [3] M.Geethanjali, K.Sathiya priya, "Combined Wavelet Transforms and Neural Network (WNN) based Fault Detection and Classification in Transmission lines", pages 1-7.
- [4] M. Kezunovic, L. Rikalo, "Detects and Classify Faults Using Neural Nets", *EEE Computer Applications in Power*, 4347, Oct. 1996.

- [5] K. M. Silva, B. A. Souza, and N. S. D. Brito, "Fault detection and classification in transmission lines based on wavelet transform and ANN," *IEEE Trans. Power Del.*, vol. 21, no. 4, pp. 2058--2063, Oct. 2006.
- [6] T. B. Littler and D. J. Morrow, "Wavelets for the analysis and compression of power system disturbances," *IEEE Trans. Power Del.*, vol. 14, no. 2, pp. 358--364, Apr. 1999.
- [7] A. M. Gaouda, M. M. A. Salama, M. R. Sultan, and A. Y. Chikhani, "Power quality detection and classification using wavelet-multiresolution signal decomposition," *IEEE Trans. Power Del.*, vol. 14, no. 4, pp. 1469--1476, Oct. 1999.
- [8] X. Xu and M. Kezunovic, "Automated feature extraction from power system transients using wavelet transform," in *Proc. Int. Conf. Power System Technology*, 2002, vol. 4, pp. 1994--1998.
- [9] C. L. Tu, W. L. Hwang, and J. Ho, "Analysis of singularities from modulus maxima of complex wavelets," *IEEE Trans. Inf. Theory*, vol. 51, no. 3, pp. 1049--1062, Mar. 2005.
- [10] T. Le-Tien, H. Talhami, and D. T. Nguyen, "Simple algorithm for wavelet maxima modulus extraction in time-scale representations,"
- [11] Ashraf .I. Megahed, A. Monem Moussa, and A.E. Bayoumy, "Usage of wavelet transform in the protection of series compensated transmission lines", *IEEE Trans on Power Delivery*, vol.21, No.3, pp.1213-1221, July 2006.
- [12] R.Malkar, V. Magdum and S.Gunda, "Transmission line fault analysis using wavelet theory", *International journal of Engineering science and Tech*, vol.4, No.6, June 2012. .
- [13] Joe-Air Jiang, Ping-Lin Fan, Ching-Shan Yu, and Jin Yi Sheu, "A Fault Detection and Faulted phase Selection Approach for transmission lines with Haar wavelet transform", *IEEE Conference on trans and dist*, vol. 1 , pp 285-289, April 2003.
- [14] S.R.Samantary, P.K.Dash and G.Panda, "Transmission line fault detection using time frequency analysis", *IEEE Conference on Indicon* , pp 162-166 , December 2005.
- [15] *E Electron. Lett.*, vol. 33, no. 5, pp. 370--371, Feb.